

MAX PROP® BOOMERANG® - BASIC PRICE LIST 2023



	BOOMERANG® 101			BOOMERANG® 111			BOOMERANG® 120			BOOMERANG® 130	BOOMERANG® 150	
	Shaft coupling : 35 ISO (★) 40 ISO 1 1/4" SAE (★) 1 1/2" SAE			Shaft coupling : 40 ISO (★) 45 ISO 1 1/2" SAE (★) 1 3/4" SAE			Shaft coupling : 45 ISO (★) 50 ISO 1 3/4" SAE			Shaft coupling : 50 ISO (★) 55 ISO 2" SAE	Shaft coupling : 55 ISO 60 ISO (★) 65 ISO 2 1/4" SAE (★) 2" 1/2 SAE	
Prop Diameter	3 Blades	4 Blades	5 Blades	3 Blades	4 Blades	5 Blades	3 Blades	4 Blades	5 Blades	5 Blades	5 blades	Prop Diameter
16" / 406												16" / 406
17" / 432												17" / 432
18" / 457	€ 5.276,00	€ 5.392,00	€ 5.991,00									18" / 457
19" / 483	€ 5.276,00	€ 5.392,00	€ 5.991,00									19" / 483
20" / 508	€ 5.276,00	€ 5.392,00	€ 5.991,00	€ 7.613,00	€ 7.835,00	€ 8.706,00						20" / 508
21" / 533	€ 5.332,00	€ 5.448,00	€ 6.053,00	€ 7.613,00	€ 7.835,00	€ 8.706,00						21" / 533
22" / 559	€ 5.332,00	€ 5.448,00	€ 6.053,00	€ 7.759,00	€ 7.981,00	€ 8.867,00	€ 8.815,00	€ 9.121,00	€ 10.134,00			22" / 559
23" / 583	€ 5.475,00	€ 5.591,00	€ 6.196,00	€ 7.759,00	€ 7.981,00	€ 8.867,00	€ 8.815,00	€ 9.121,00	€ 10.134,00			23" / 583
24" / 610				€ 7.883,00	€ 8.105,00	€ 9.006,00	€ 8.940,00	€ 9.246,00	€ 10.273,00	€ 13.287,00		24" / 610
25" / 635				€ 8.026,00	€ 8.248,00	€ 9.148,00	€ 8.940,00	€ 9.246,00	€ 10.273,00	€ 13.287,00		25" / 635
26" / 660							€ 9.169,00	€ 9.474,00	€ 10.527,00	€ 13.377,00	€ 19.336,00	26" / 660
27" / 685							€ 9.169,00	€ 9.474,00	€ 10.527,00	€ 13.377,00	€ 19.336,00	27" / 685
28" / 711										€ 13.440,00	€ 19.433,00	28" / 711
29" / 737										€ 13.440,00	€ 19.433,00	29" / 737
30" / 762										€ 13.507,00	€ 19.530,00	30" / 762
31" / 787										€ 13.507,00	€ 19.530,00	31" / 787
32" / 813										€ 13.574,00	€ 19.628,00	32" / 813
33" / 838										€ 13.574,00	€ 19.628,00	33" / 838
34" / 864										€ 13.642,00	€ 19.726,00	34" / 864
35" / 890										€ 13.642,00	€ 19.726,00	35" / 890

(★) LOWER KEYWAY. THE MAXIMUM PROPELLER DIAMETER ALLOWED WITH LOWER KEYWAY IS 2" LESS COMPARED TO THAT SHOWN ON TABLE

MAX PROP SRL

Viale Carlo Espinasse, 101 - 20156 Milano - Italy | www.maxprop.it | info@maxprop.it
Tel. +39 02.33.40.43.25 - Fax +39 02.38.000.791 | P.IVA 07610270154



TECHNICAL FORM

Request a free sizing and quote for the most suitable propeller for your vessel



1. CLIENT

Name Phone Email

2. VESSEL

Model Weight Waterline Length

3. ENGINE

Engine model Maximum Power
 Engine Max RPM Reduction Ratio Propeller Max RPM

4. EXISTING PROPELLER (if present)

Diameter Pitch
 Type: fixec feathering folding 2 blades 3 blades 4 blades 5 blades
 Eventual problems with the existing propeller

5. REQUESTED MAX PROP PROPELLER

Diameter 2 blades 3 blades 4 blades 5 blades
 Coupling taper Saildrive
 Direction of rotation left-hand right-hand

6. TAPERED SHAFT DIMENSIONS

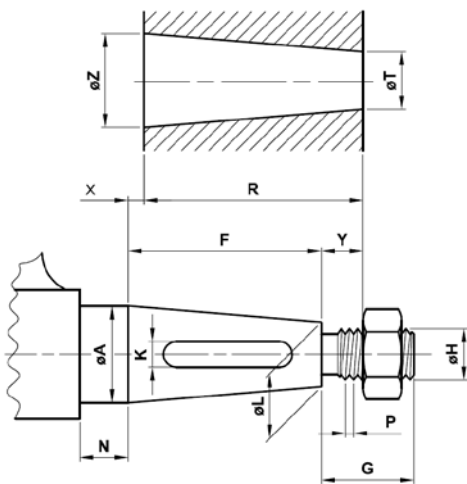

$\phi A =$ $G =$
 $F =$ $N =$
 $\phi L =$ $\phi H =$
 $K =$ $P =$
 Taper = 1 : $\frac{F}{A - L}$ ISO standard **1 : 10**
 English standard **1 : 12**
 SAE standard **1 : 16**
 Special **1 :**

If it is not possible to find this data, we will be glad to help you with the information at your disposal.

7. SPACE AVAILABLE

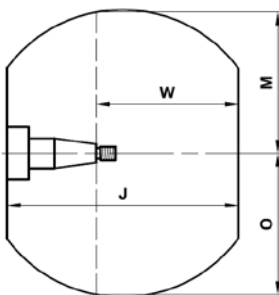

$M =$
 $O =$
 $W =$
 $J =$

rev. 03/10/23

MAX PROP SRL

Viale Carlo Espinasse, 101 - 20156 Milano - Italy | www.maxprop.it | info@maxprop.it
 Tel. +39 02.33.40.43.25 - Fax +39 02.38.000.791 | P.IVA 07610270154

