



**MAX PROP®**

Made in Italy - Since 1975

# Instruction Manual

**BOOMERANG™**

AUTOMATIC FEATHERING PATENTED PROPELLER



## INDEX

1. Introduction
2. Checks to be carried out before mounting the Max Prop propeller on the propeller shaft
3. How to mount the Max Prop propeller on the propeller shaft
4. Checks to be carried out before launching the boat
5. How to determine the optimal forward motion pitch and / or the optimal backwards motion pitch of the propeller
6. Description of the patented system for setting and / or varying the pitch
  - 6.1 How to set the forward motion pitch of the propeller
  - 6.2 How to set the backwards motion pitch of the propeller
  - 6.3 How to vary the forward motion pitch and / or the backwards motion pitch of the propeller
    - 6.3.1 How to vary the pitch if you have a set of screws/rods
    - 6.3.2 How to vary the pitch if you have not a set of screws/rods
  - 6.4 How to know the value of the pitch set on your propeller
7. Important instructions for the propeller use and maintenance
8. How to slip the propeller off from the propeller shaft
9. Identification features of your MAX PROP®

## 1. INTRODUCTION

Thank you for choosing an automatic feathering propeller MAX PROP®. This instruction manual will be used to answer your questions on installation and use of the propeller. Please read this manual carefully and verify the correct working of the propeller before installing it on your boat.

The propeller is supplied already assembled for right or left rotation (according to information received when the order was made) and with the required pitch and required diameter, so that it can be directly installed on the propeller shaft as a common fixed-pitch propeller. Please note that the MAX PROP® propeller parts are not interchangeable, so make sure that if you receive more than one propeller at the same time (for example if two propellers have to be installed on a boat, like in a catamaran) you must therefore be very careful not to interchange parts.

## 2. CHECKS TO BE CARRIED OUT BEFORE MOUNTING THE MAX PROP PROPELLER ON THE PROPELLER SHAFT

- a. Check that the values of the pitch and diameter set on your propeller are optimal for your boat. If you have any doubts please refer to sections 5 and 6, concerning the calculation, setting and variation of the propeller pitch.
- b. Check that the direction of your propeller rotation coincides with the direction of the shaft rotation of your boat. If you have doubts about the shaft rotation, put into forward gear and look the propeller from the stern of the boat to the bow. If the shaft rotates clockwise, the rotation is right-handed; by contrast, if it rotates counterclockwise, the rotation is left-handed.

### 3. HOW TO MOUNT THE MAX PROP PROPELLER ON THE PROPELLER SHAFT

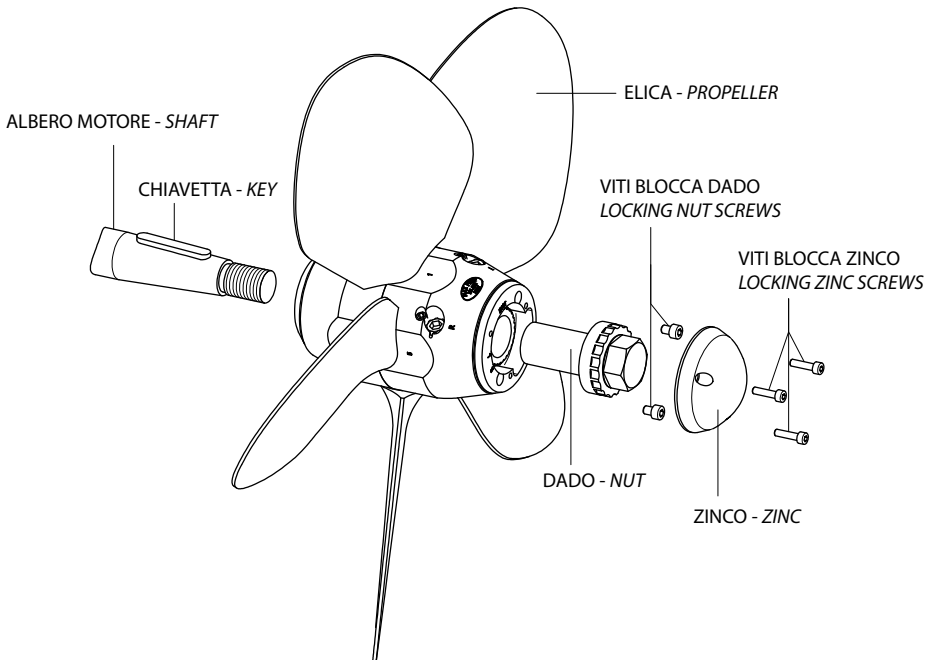

fig. 1

Please carry out the various operations referring to fig. 1.

- a. Fit the already assembled propeller on the propeller shaft, as a fixed-pitch propeller.
- b. Verify that the key has the appropriate size: it should have clearance on the upper surface (in order to prevent the propeller from being brought off center), but between the side surfaces there should be no clearance. To verify this, we suggest to insert the propeller on the propeller shaft without mounting the key and to trace, with a marker or a point, the precise position in which the propeller hub stops onto the conical shaft. Then remove the propeller and mount it again after having inserted the key in its seat on the propeller shaft. If the hub reaches the same position as before, the height

of the key is correct. If this is not the case, the thickness of the key must be reduced so that the hub penetrates to the position previously traced.

- c. Insert and tighten the nut and lock it by using the two locking-nut screws which should be inserted and tighten into the proper seats. The tightening torque of the nut must not be too high (do not exceed the value of 50 - 80 Newton/meter, which corresponds to a load of 5 - 8 kg on a lever of one meter in length). This is to avoid that (in case of any irregularity in the work of the propeller shaft) the shank and the head of the nut are forced and stuck inside their own seat, thus making the unscrewing difficult in case you need to remove the propeller. To be sure that the above does not occur, it is recommended, (after having screwed the nut up to abutment and before inserting the two locking-nut screws), to make the nut turn a few times, so as to check that it rotates freely both in screwing and unscrewing. Then return the nut to the stop position and secure it with the two locking-nut screws.

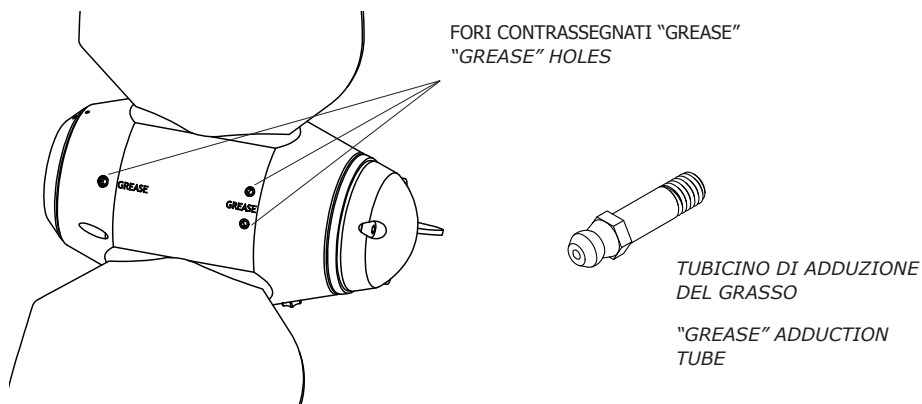

fig. 2

- d. Fill completely the propeller body with fluid grease, by using a greasing tool, through the apposite holes marked "GREASE" (Fig.2). Start from a first hole of your choice and proceed with each other hole as follows:
- Remove the grub screw from the hole.
  - Screw the grease adduction tube (supplied with the propeller) into the hole. Inject the grease into the propeller body by pressure. Keep the

injection pressure applied until the grease starts to seep to the outside of the propeller through the slits and the rotating joints between the central part and the hub.

- Remove the grease adduction tube and close the hole by tightening the grub screw.
  - Repeat the same operation with each other hole marked "GREASE" until the propeller body is completely filled with fluid grease.
- e. The grease must be fluid and must pour to ensure that, even without the thrust of the greasing tool, it will continue to seep from the propeller body, ensuring the lubrication of the surfaces that rotate reciprocally.

#### 4. CHECKS TO BE CARRIED OUT BEFORE LAUNCHING THE BOAT

- a. Lock the propeller shaft.
- b. Keeping the propeller shaft locked, verify that the propeller body is able to freely rotate around the shaft itself, so that the blades may switch from the forward motion position to the backwards motion position and vice versa. For the MAX PROP® BOOMERANG™ propeller, in order to reach the position in forward motion gear, it is necessary to apply a considerably greater effort than the effort required to reach the position of backwards motion gear. The blades must not be grabbed with the fingers, but they have to be simply pushed with the palm of the hand open (thereby simulating the water force). At the end of the stroke, the blade angles must be equal to the blade angle chosen and preset by the user and the direction of rotation must be that of the propeller shaft.

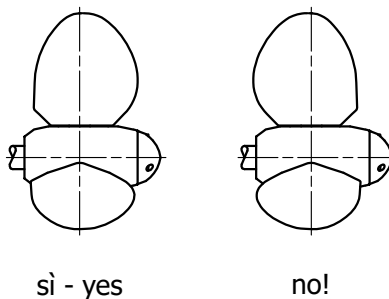

fig. 3

- c. In the feathering position the blades must be perfectly aligned and oriented as in fig. 3.
- d. Verify that the propeller is full of fluid grease (it must pour) and seep to the outside of the propeller.
- e. Make sure that the propeller is protected from galvanic corrosion by applying the proper zinc anode on the propeller and drive shaft.
- f. Be sure that the values of the forward and backwards motion pitch set on the propeller you received correspond to those optimal for your boat. If you have any doubts please refer to the sections 5 and 6 concerning the calculation and the adjustment of the propeller pitch.

## **5. HOW TO DETERMINE THE OPTIMAL FORWARD MOTION PITCH AND / OR THE OPTIMAL BACKWARDS MOTION PITCH OF THE PROPELLER**

The diameter and pitch must be calculated as if MAX PROP® EASY/WHISPER were a common fixed-pitch propeller. With respect to traditional propellers, MAX PROP® EASY/WHISPER allows the users to adjust the pitch according to their needs. This great advantage allows the pitch to be optimized if during navigation the performance is not completely satisfactory or in case of changed characteristics of the propulsion system. If the engine does not reach the operating number of revolutions, then the blade angle  $\alpha$  must be decreased; if, on the contrary, the operating number of revolutions is exceeded, then the angle  $\alpha$  must be increased. The fig.4 below shows the theoretical pitches in millimeters corresponding to the different blade's angles for a number of propeller diameters.

With good approximation we can consider that, at the same RPM, the boat speed varies directly with the variation of angle  $\alpha$ . Or that, at the same boat speed, the RPM of the engine varies inversely with the variation of the angle  $\alpha$ . For example if the angle  $\alpha$  is increased by 10%, at the same RPM, the boat speed will increase by 10% and vice versa . Or, if the angle  $\alpha$  is increased by 10%, at the same boat speed, the RPM of the engine will decrease by 10% and vice versa.



		Propeller diameter (millimeters)										
		300	350	400	450	500	550	600	650	700	750	800
$\alpha$ Blades inclination angle (degrees)	10°	100	115	130	150	170	185	200	215	230	250	265
	12°	120	140	160	180	200	220	240	260	280	300	320
	14°	140	165	190	210	235	260	280	305	330	350	375
	16°	160	190	215	245	270	300	325	350	380	405	430
	18°	180	215	245	275	305	335	365	400	430	460	490
	20°	205	240	275	310	345	375	410	445	480	515	550
	22°	230	265	305	340	380	420	455	495	535	570	610
	24°	250	295	335	375	420	460	505	554	585	630	670
	26°	275	320	370	415	460	505	550	590	645	690	735
	28°	300	350	400	450	500	550	600	650	700	750	800
	30°	325	380	435	490	545	600	655	705	760	815	870

fig. 4

### PRACTICAL EXAMPLE

The user can reach a maximum RPM = 2,730 into forward gear, while at the same speed he would like his engine to reach an RPM = 3,000. It is therefore necessary to reduce the angle  $\alpha$  previously set on the propeller. If the propeller was set with an angle  $\alpha$  of 22 °, the new angle  $\alpha$  should be 20 °. The proportion is:  $2.730 \times 22 = 3.000 \times 20$ . That is, at the same boat speed if you multiply the RPM value detected in navigation by the value of the corresponding angle  $\alpha$ , you get as a result, a constant.

## 6. DESCRIPTION OF THE PATENTED SYSTEM FOR SETTING AND / OR VARYING OF THE PITCH

*(for convenience all the propeller pitches will be "improperly" expressed in degrees)*

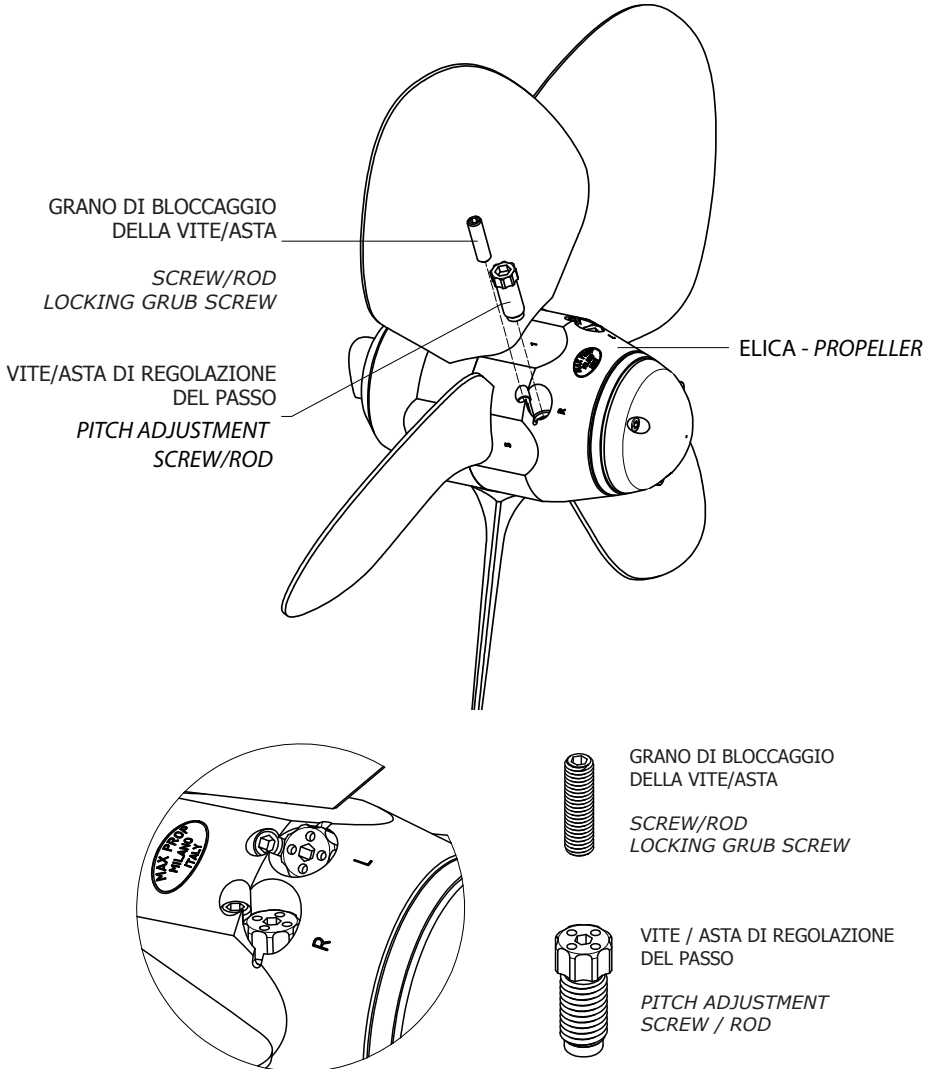

fig. 5

On the body of each propeller are two threaded holes ( housings), marked with letters “R” and “L”; a screw/rod is inserted in each hole. The pitch of the propeller, both in forward and backwards position, can be easily varied by changing how deeply each screw/rod penetrates the propeller body. If the propeller is right-handed, the forward motion pitch can be changed by acting on the screw/rod housed in the hole “R” (right) and the backwards motion pitch by acting on the screw/rod housed in the hole “L” (left). On the contrary, if the propeller is left-handed the forward motion pitch can be changed by acting on the screw/rod housed in the hole “L” and the backwards motion pitch by acting on the screw/rod housed in the hole “R”.

Each MAX PROP® propeller is supplied with two screws/rods already inserted in the propeller body. A screw/rod sets the forward motion pitch; the other screw/rod sets the backwards motion pitch. The pitches, both in forward and backwards position, are the ones requested at order confirmation.

## **6.1 HOW TO SET THE FORWARD MOTION PITCH OF THE PROPELLER**

- a. The forward motion pitch increases by increasing the penetration depth of the screw/rod supplied in the propeller body or if a longer screw/rod is inserted. Vice versa decreases by decreasing the penetration depth of the screw/rod supplied in the propeller body or if a shorter screw/rod is inserted.
- b. Each screw/rod used for setting the pitch is provided with a stamped even number (consisting of 2 digits), corresponding to a precise propeller pitch. The higher the number stamped on the screw/rod, the longer the screw/rod, and the greater is the corresponding forward motion pitch.
- c. To make the propeller assume the forward motion pitch stamped on the screw/rod, it is sufficient to completely screw, up to abutment, the screw/rod into the respective housing. Then lock the screw/rod in said position with a threaded grub screw. *NOTE: If in its abutment/stroke position, the grub screw does not coincide with any of the grooves dug into the head of the screw/rod, it is necessary to slightly unscrew the screw/rod until the nearest groove coincides with the position of the grub screw.*

## **PRACTICAL EXAMPLE CONCERNING THE FORWARD MOTION PITCH**

The number 18 is stamped on the screw/rod. As the number 18 consists of two digits, the screw/rod must be used to set the forward motion pitch. If the screw/rod 18 is completely screwed up to abutment, the forward motion pitch of the propeller will be 18 degrees.

## **6.2 HOW TO SET THE BACKWARDS MOTION PITCH OF THE PROPELLER**

- a. The backwards motion pitch increases if the penetration depth of the screw/rod in the propeller body is reduced or if a shorter screw/rod is inserted in the respective housing, vice versa decreases by increasing the penetration depth of the screw/rod in the propeller body or if a longer screw/rod is inserted in the respective housing.
- b. There are three screws/rods available for setting the backwards motion pitch, stamped respectively with the following numbers: 1, 2, 3. The screw/rod stamped number 1 is the longest and corresponds to the backwards motion pitch of 16 degrees. The screw/rod stamped number 2 has an intermediate length and corresponds to the backwards motion pitch of 20 degrees. The screw/rod stamped number 3 is the shortest and corresponds to the backwards motion pitch of 24 degrees.
- c. To make the propeller assume the backwards motion pitch of 16 degrees, it is sufficient to completely screw, up to abutment, the screw/rod stamped number 1. Then lock, with a threaded grub screw, the screw/rod in its housing. To make the propeller assume the backwards motion pitch of 20 degrees, it is sufficient to completely screw, up to abutment, the screw/rod stamped number 2. Then lock, with a threaded grub screw, the screw / rod in its housing. To make the propeller assume the backwards motion pitch of 24 degrees, it is sufficient to completely screw, up to abutment, the screw/rod stamped number 3. Then lock, with a threaded grub screw, the screw / rod in its housing.

## **6.3 HOW TO VARY THE FORWARD MOTION PITCH AND THE BACKWARDS MOTION PITCH OF THE PROPELLER**

Max Prop can provide on request additional screws/rods ( a “screws/rods set”) for varying both the forward motion pitch (screws stamped with the respective even numbers of two digits) and the backwards motion pitch (screws stamped with the respective numbers of one digit).

### **6.3.1 HOW TO VARY THE PITCH WITH A SET OF SCREWS/RODS**

- a. Remove the threaded grub screw that locks the pitch adjustment screw/rod you want to vary.
- b. Remove the screw/rod (corresponding to the first pitch) from the propeller body and screw up to abutment, in the same housing, a second screw/rod having stamped a different number from the one stamped on the removed first screw/rod. Then lock the new screw/rod in its housing with the threaded grub screw. The new propeller pitch will be the one stamped on the second screw/rod.

### **6.3.2 HOW TO VARY THE PITCH WITHOUT A SET OF SCREWS/RODS**

The patented MAX PROP® propeller pitch adjustment system offers also the possibility to vary the forward motion pitch and the backwards motion pitch even without a set of screws/rod. In fact, it is possible to obtain the new pitch simply by unscrewing, by a precise angle, the screw/rod already inserted in the propeller body. It is thus possible to obtain all the forward motion pitches lower than or equal to the number pitch stamped on the screw/rod for adjusting the forward motion pitch, and all the backwards motion pitches higher than or equal to the pitch stamped on the screw/rod for adjusting the backwards motion pitch.

- a. All of the MAX PROP EASY/WHISPER propellers have been sized so that, by unscrewing one complete turn (360°) each forward pitch adjustment screw/rod, the forward motion pitch decreases by four degrees. By unscrewing one complete turn (360°) each backwards pitch adjustment screw/rod, the backwards motion pitch increases by four degrees.

### **PRACTICAL EXAMPLE CONCERNING THE FORWARD MOTION PITCH**

In the housing for the forward motion pitch it has been screwed, up to abutment, a screw/rod stamped 22, therefore the propeller has now a forward motion pitch of 22 degrees. By unscrewing this screw/rod by one complete turn, the propeller will take a new forward motion pitch of 18 degrees ( $22-4=18$ ). It is therefore possible to set a forward motion pitch of 18 degrees without having the screw/rod with the number 18 stamped on it.

### **PRACTICAL EXAMPLE CONCERNING THE BACKWARDS MOTION PITCH**

In the housing for the backwards motion pitch it has been screwed, up to abutment, the screw/rod stamped number 1, therefore the propeller has a backwards motion pitch of 16 °. By unscrewing this screw/rod by one complete turn, the propeller will take a new backwards motion pitch of 20 ° ( $16 + 4 = 20$ ). It is therefore possible to set a backwards motion pitch of 20 ° without having the screw/rod with the number 2 stamped on it.

- b. Eight equidistant grooves are carved in the head of each screw/rod. These grooves have dual capacity: the first is the one described in the previous practical examples, that is locking the screw/rod up to abutment by fastening it with a threaded grub screw. The second function is to precisely define an intermediate rotation (not in the stop/end position) and lock the screw/rod in the said intermediate position. It is in fact possible to unscrew each screw/rod even by a single interval between one groove and the next, or one eighth of a turn (since the grooves are eight), and lock the screw/rod in said position.

- c. As the unscrewing of a complete turn of each forward pitch adjustment screw/rod decreases the forward motion pitch by four degrees, the unscrewing of a single interval between one groove and the following one will decrease the forward motion pitch of half a degree ( $4 : 8 = 0.5$ ). Unscrewing a single interval between one groove and the following one of each backwards pitch adjustment screw/rod will increase the backwards motion pitch by half a degree ( $4 : 8 = 0.5$ ).

### **PRACTICAL EXAMPLE CONCERNING THE FORWARD MOTION PITCH**

The screw/rod stamped number 22 has been screwed into its seat up to abutment, therefore the propeller has a forward motion pitch of  $22^\circ$ . Starting from the stroke position of this screw/rod, if you loosen three grooves of the screw/rod, the propeller pitch will decrease by  $1.5^\circ$  ( $0.5 \times 3 = 1.5$ ). The propeller will therefore take a new forward motion pitch of  $20.5^\circ$  ( $22 - 1.5 = 20.5$ ).

### **PRACTICAL EXAMPLE CONCERNING THE BACKWARDS MOTION PITCH**

A screw/rod stamped number 1 has been screwed in its seat up to abutment, therefore the propeller has a backwards motion pitch of 16 degrees. By unscrewing the screw/rod of three grooves, the propeller pitch will increase by 1,5 degrees ( $0.5 \times 3 = 1,5$ ). The propeller will therefore assume a new backwards motion pitch of 17,5 degrees ( $16 + 1,5 = 17,5$ ).

## 6.4 HOW TO KNOW THE VALUE OF THE PITCH SET ON YOUR PROPELLER

If the two screws/rods have been both completely screwed up to abutment in its housings, the forward and the backwards motion pitch of the propeller correspond to the numbers stamped on the respective screws/rods.

If the screw/rod is not completely screwed up to abutment in its housing, proceed as follows to know the value of the pitch:

- a. Tighten the screw/rod up to abutment while counting with attention the number of groove intervals it rotates to come into abutment (and therefore how many half degrees the propeller pitch has changed). Write down this variation.
- b. Remove the screw/rod and read the number stamped on it.
- c. If the screw/rod is the one intended to adjust the forward motion pitch, the so-founded aforesaid pitch variation must be detracted from the value of the pitch stamped on such screw/rod, on the contrary, if the screw/rod is the one intended to adjust the backwards motion pitch, the so-founded aforesaid pitch variation must be added to the value of the pitch stamped on such screw/rod.

### PRACTICAL EXAMPLE CONCERNING THE FORWARD MOTION PITCH

To reach the abutment position the forward pitch adjustment screw /rod has rotated of 5 intervals, that is the forward motion pitch has increased of 2,5 degrees (  $5 \times 0,5 = 2,5$ ). The number stamped on the screw/rod is 22 (corresponding to a forward motion pitch of 22 degrees). The propeller forward pitch was therefore set at 19.5 degrees (  $22 - 2,5 = 19,5$ ).



## **PRACTICAL EXAMPLE CONCERNING THE BACKWARDS MOTION PITCH**

To reach the abutment position the backwards pitch adjustment screw /rod has rotated of 5 intervals, that is the backwards motion pitch has decreased by 2,5 degrees ( $5 \times 0,5 = 2,5$ ). The number stamped on the screw/rod is 1 (corresponding to a backwards motion pitch of 16 degrees). The propeller backwards pitch was therefore set at 18.5 degrees ( $16 + 2,5 = 18,5$ ).

## **7. IMPORTANT INSTRUCTIONS FOR THE PROPELLER USE AND MAINTENANCE**

- a. The backwards motion must always be engaged starting from the forward motion position, to avoid the thrust direction of the propeller to be reversed. Therefore, before putting into the reverse gear, the forward gear has to be put into for a while.
- b. To arrange the blades in the feathered position, the rotation of the propeller shaft has to be locked while the boat is travelling forward and the propeller blades are arranged in the forward motion position. To verify if the propeller blades actually reach the feathered position it is sufficient, while the boat is still travelling forward, to make the propeller shaft free to rotate by putting into the neutral gear. If the propeller shaft starts rotting, it means that the blades are not arranged in the feathered position and, therefore, it is recommended to fill the propeller body with a very fluid grease (it must pour).
- c. When the boat sails with the engine off, it is suggested to leave the propeller shaft free to rotate by putting the gear in neutral. However, you should never sail with the reverse gear engaged.
- d. Verify that the grease is very fluid so that it pours and seeps to the outside of the propeller, thereby assuring the lubrication of the surfaces able to rotate reciprocally. This way, the blades will be arranged in their feathered position also if the boat travels at low speed.

- e. Protect the propeller against galvanic corrosion by applying a sufficient mass of zinc. Replace the zinc anodes every year even if they have not been corroded and check that there is good electrical contact between the zinc, the propeller bronze and the propeller shaft (the contact surfaces between the zinc and the bronze must be cleaned with abrasive cloth if they have incrustations).

## 8. HOW TO SLIP THE PROPELLER OFF FROM THE PROPELLER SHAFT

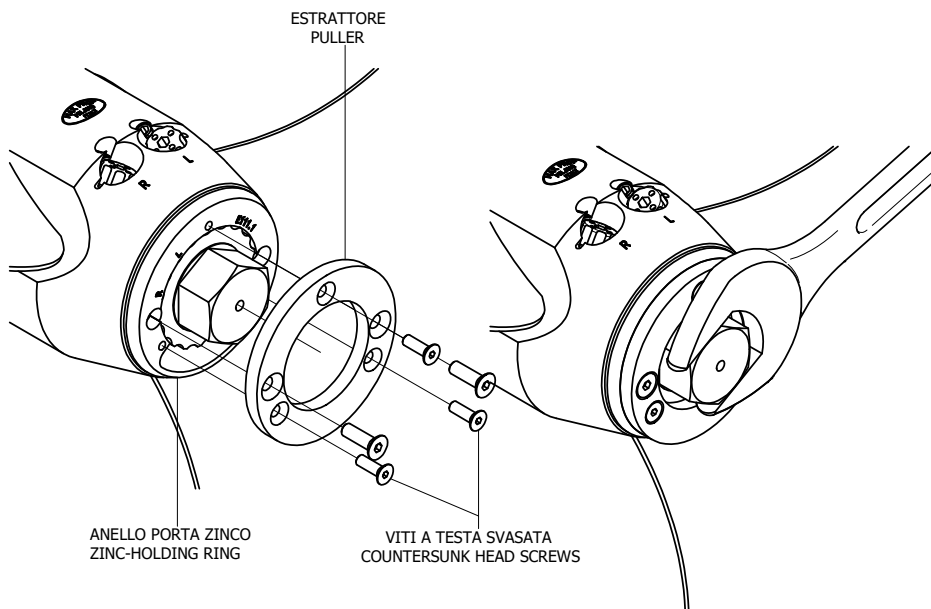

fig. 7

Referring to fig. 7, operate as follows:

- a. Remove the zinc.
- b. Remove the two locking-nut screws.

- c. Verify that the nut is free to loosen and, at the same time, verify which is the rotation direction for the unscrewing (usually the nut loosens by rotating anticlockwise).
- d. Screw the nut again until it is moved again in abutment against the propeller.
- e. Fasten a puller (that is a perforated washer), supplied on request, on the zinc-holding ring by means of countersunk-head screws.
- f. In each threaded hole of the zinc-holding ring, a countersunk-head screw for locking the extractor (perforated washer) must be inserted. Check that all the screws work together to hold the extractor against the zinc holder ring. To do this it is necessary that the longer countersunk-head screws are screwed into the holes where the nut locking screws were housed; while the shorter countersunk screws are screwed into the holes where the zinc locking screws were housed.
- g. It is very important to verify that each countersunk-head screw is neither too long or too short. Each screw must be screwed into its threaded hole for a length not less than its own diameter. The same screw, when it is completely screwed (and tightened against the puller) must not touch the bottom of its threaded hole.
- h. Unscrewing the nut carefully, verifying that all the screws collaborate on bearing the load necessary for extracting the propeller. In other words that all the countersunk-head screws hold the perforated washer (puller) against the zinc holder ring.
- i. Increase the unscrewing torque to unscrew the nut progressively. We recommend to not exceed the 200 Newton/meter value ( which corresponds to a load of 10-20 kg on a one meter length lever) and to apply the unscrewing stress by interposing pauses.
- j. After each pause, and before reapplying the nut unscrewing load, it is important to check that all the countersunk-head extractor fastening screws have not loosened. In the event of loosening, it is necessary to tighten again each screw against the extractor.
- k. When the unscrewing of the nut has tensioned all the screws, tap the propeller body with a plastic mallet. These blows will cause the propeller hub to come off the propeller shaft.

## 9. IDENTIFICATION FEATURES OF YOUR MAX PROP®

it is useful to fill in and keep the following data

### Propeller shaft dimensions

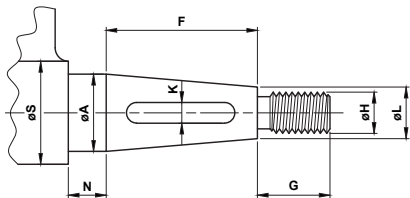

A =	<input type="text"/>	mm	G =	<input type="text"/>	mm
F =	<input type="text"/>	mm	N =	<input type="text"/>	mm
L =	<input type="text"/>	mm	S =	<input type="text"/>	mm
K =	<input type="text"/>	mm	Passo della filettatura:		
H =	<input type="text"/>	mm	<input type="text"/> mm		
			F	Italiana/ISO	1 : 10 <input type="radio"/>
Conicità = 1 :				Inglese	1 : 12 <input type="radio"/>
			A - L	Americana/SAE	1 : 16 <input type="radio"/>
			Speciale	1 :	<input type="text"/> <input type="radio"/>

The propeller was installed on the boat on date .....

Direction of propeller rotation (right-handed or left-handed).....

Propeller diameter (in mm and/or inch) .....

Forward motion pitch (in degrees) .....

Backwards motion pitch (in degrees) .....

Number stamped on the forward pitch adjustment  
screw / rod inserted in the propeller body .....

Number stamped on the backwards pitch adjustment  
screw / rod inserted in the propeller body .....

RPM max (maximum rotation speed the  
engine can reach during navigation) .....

Spare parts reference code .....



## GENERAL SALE CONDITIONS OF MAX PROP® PROPELLERS

- a. All the components of each propeller must not be modified in any way or for any reason.
- b. All the components of each propeller are not interchangeable between a propeller and the other.
- c. The propeller must be used following the instructions of the manual enclosed with the prop, paying particular attention to the warnings.
- d. The non-compliance of the conditions a, b and c means the loss of the warranty.
- e. Max Prop Srl is to repair and replace free of charge the original pieces of the propeller which may result damaged due to construction defects or due to material defects. Max Prop Srl will not pay, for any reasons, any refund whatsoever, not even partial. The warranty granted by Max Prop Srl is therefore limited exclusively to the repair or replacement of any possible defective propeller and does not include any damage compensation refund, or claim of any kind.
- f. The reparations in warranty, that might be needed, will be carried on exclusively by Max Prop Srl at its own workshop in Italy - Milan – Viale Carlo Espinasse 101. The customer will, at his own charge and care, send the defective pieces to our workshop.
- g. This warranty is valid 12 months starting from the date of propeller delivery.
- h. Any possible controversy will fall within the jurisdiction of the Milan Courts-Italy.
- i. The transport cost charged in the invoice from Max Prop doesn't include any insurance. The customer notes that the insurance (even if pre paid from Max Prop), from the order confirm and from the payment of the proforma, is not included on the transport. In case the customer wants to insure the shipment, he will have to get in touch directly with the transporter and agree an upgrade of the shipment charge with an insurance cover policy. In no way Max Prop Srl can be considered responsible for any loss, damage or delay starting from when the goods are given to the courier. The customer itself must be considered responsible for any loss, damage or delay due to the transport, in case he has chosen not to stipulate a transport insurance with the courier.
- j. These conditions of sale are integral part of any purchase contract agreed with Max Prop Srl.
- k. The official and binding text of these general sale conditions is the one edited in Italian, any translations in other languages are a form of courtesy. It is established that the Italian text will be the only value text.
- l. The customer confirms that the purchase price of the propeller has been established considering his acceptance of the present general conditions of sale. With this acceptance the customer excludes any type of claim.





manufactured by: MAX PROP®  
viale Carlo Espinasse, 101 - 20156 Milano - ITALY  
tel. +39 02 33 404 325 - skype: maxprop1  
[www.maxprop.it](http://www.maxprop.it) - [info@maxprop.it](mailto:info@maxprop.it)

